

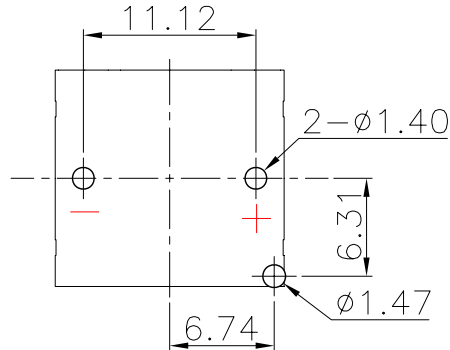

REV.	ECN NO.	REVISED	DATE

- 1.MATERIAL:  
 a.HOUSING:PPA  
 b.CONTACT:PHOSPHOR BRONZE  
 (SURFACE PLATING:AU1U")  
 SEE ORDERING INFORMATION
- 2.ELECTRIC:  
 a.CONTACT RESISTANCE: 30 MILLIOHMS MAX  
 b.INSULATION RESISTANCE: 1000 MEGA OHMS MIN  
 c.DIELECTNIC VOLTAGE: 500V AC ONE SEC LEVEL  
 d.OPERATING TEMPERATURE: -25°C~ +85°C

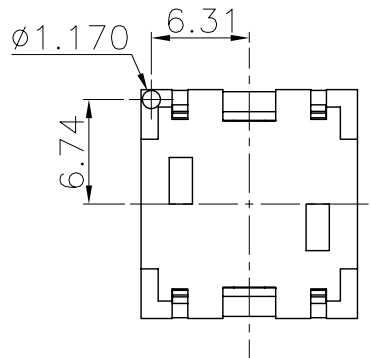
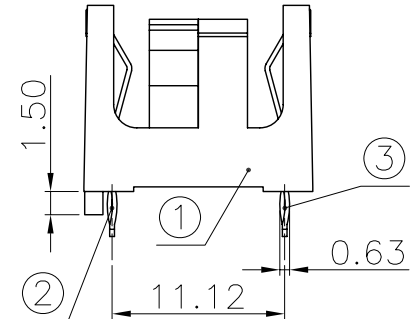
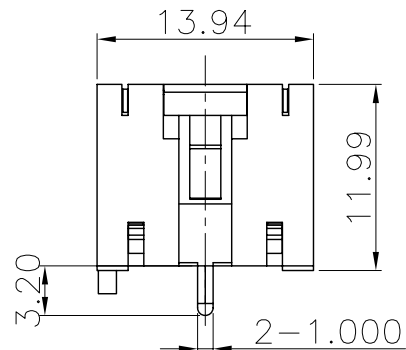
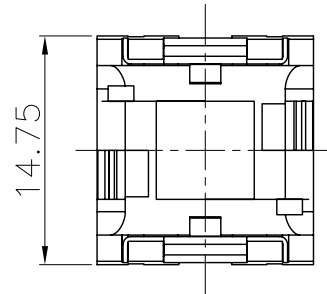

PCB Layout Diagram  
Top View

ORDERING INFORMATION  
**BS-09-A\*\*\*002**

电池座系列  
 BS-09系列  
 DIP 90° TYPE

PLATING:  
 A-Au1U"  
 J-Ni100U"~120U"  
 K-Sn100U"~120U"

MATERIAL:  
 1A-PBT BLACK  
 1B-PA66 BLACK  
 2A-PPA BROWN  
 2B-PPA BLACK  
 3A-PPS BROWN  
 3B-PPS BLACK  
 4A-LCP WHITE  
 4B-LCP BLACK



3	TERMINAL(-)	1	PHOSPHOR BRONZE, T=0.30mm	Gold Plating and Ni Under-Plating
2	TERMINAL(+)	1	PHOSPHOR BRONZE, T=0.30mm	Gold Plating and Ni Under-Plating
1	HOUSING	1	PPA	BLACK
NO.	PART NAME	Q'TY	MATERIAL	PLATING & COLOR

UNLESS OTHERWISE SPECIFIED TOLERANCES		OXUN 深圳市欧迅光电科技有限公司 SHENZHEN OXUN PHOTOELECTRIC TECHNOLOGY CO., LTD	
DECIMALS: X :±0.30 X.X :±0.25 X.XX :±0.20 X.XXX :±0.10	ANGLES: X :±1° X.X :±0.5°	DSND YangFeng	DATE 2017-07-13
WEIGHT: 1.91g		CHKD ZhouRuicai	DATE 2017-07-13
SHEET 1 OF 1		APVD XueShunyang	DATE 2017-07-13
UNIT: mm	REV.: A/0	SCALE: 2:1	VIEW:
OBJECT: MY	TITLE: BS-2AG13-9 DIP	SIZE: A4	PART NO.: BS-09-A2BA002
			DRAW NO.:MY-CP-0084